

Model Lighthouse Project

This project was designed for a model lighthouse to flash a lamp in a simple sequence: two flashes of 2s with a short gap of 1s, followed by a longer gap of 5s before repeating the sequence.

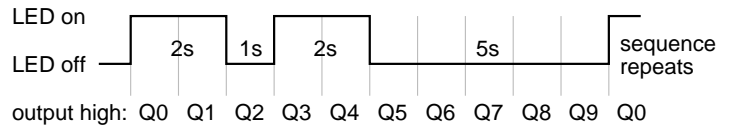

The 555 timer is connected as an astable to provide clock pulses for the 4017 counter. The 4017 has ten outputs (Q0 to Q9) and each one becomes high ('on') in turn as the clock pulses are received. Outputs Q0, Q1, Q3 and Q4 are combined with diodes to produce the flash sequence. A transistor amplifies the current to power the lamp, or LED if you prefer (a 470Ω LED resistor is included on the stripboard layout). The 1MΩ preset controls the time period (T) of the 555 astable from about 0.1 to 1.5s, for example set T = 1s. For a different flash sequence connect the diodes to combine different 4017 outputs (Q0-Q9). If the full count from 0 to 9 is not required one of outputs can be connected to the reset input (pin 15). For example connecting Q8 (pin 9) to reset (pin 15) reduces the long gap at the end of the sequence to 3s (with T=1s).

Parts Required

- resistors: 470, 2k2, 22k, 100k
- capacitors: 0.1μF, 1μF 16V radial
- diodes: 1N4148 × 4
- transistor: BC108 (or equivalent)
- 1M preset, horizontal
- 6V 60mA MES lamp
- MES lampholder
- 555 timer IC, such as NE555
- 4017 counter IC
- DIL sockets for ICs: 8-pin, 16-pin
- on/off switch
- battery clip
- 9V battery box for 6 × AA cells
- stripboard: 19 rows × 21 holes

Stripboard Layout

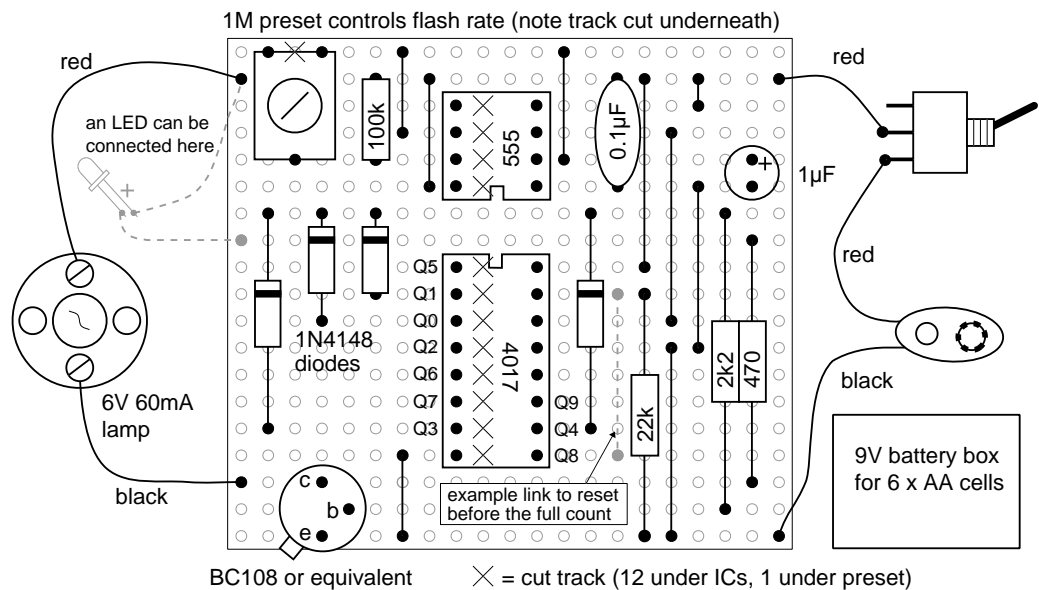

Circuit diagram

