

# Traffic Light Project

This project operates red, amber and green LEDs in the correct sequence for a single UK traffic light. The time taken for the complete red - red & amber - green - amber sequence can be varied from about 7s to about 2½ minutes by adjusting the 1M preset. Some amber LEDs emit light that is almost red so you may prefer to use a yellow LED. The 555 astable circuit provides clock pulses for the 4017 counter which has ten outputs (Q0 to Q9). Each output becomes high in turn as the clock pulses are received. Appropriate outputs are combined with diodes to supply the amber and green LEDs. The red LED is connected to the ÷10 output which is high for the first 5 counts (Q0-Q4 high), this saves using 5 diodes for red and simplifies the circuit.

4017 counter outputs high	LEDs ●●● = LED on		
	red	amber	green
Q0 and ÷10	●		
Q1 and ÷10	●		
Q2 and ÷10	●		
Q3 and ÷10	●		
Q4 and ÷10	●	●	
Q5			●
Q6			●
Q7			●
Q8			●
Q9		●	

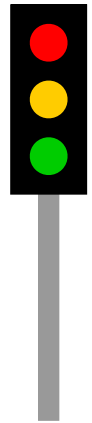

## Parts Required

- resistors: 470 × 3, 22k, 100k
- capacitors: 0.1µF, 1µF 16V radial, 10µF 16V radial
- diodes: 1N4148 × 6
- LEDs: red, amber (or yellow), green
- 1M preset, horizontal
- stripboard: 20 rows × 21 holes
- 555 timer IC, such as NE555
- 4017 counter IC
- DIL sockets: 8-pin, 16-pin
- on/off switch
- battery clip for 9V PP3

## Stripboard Layout and LED connections

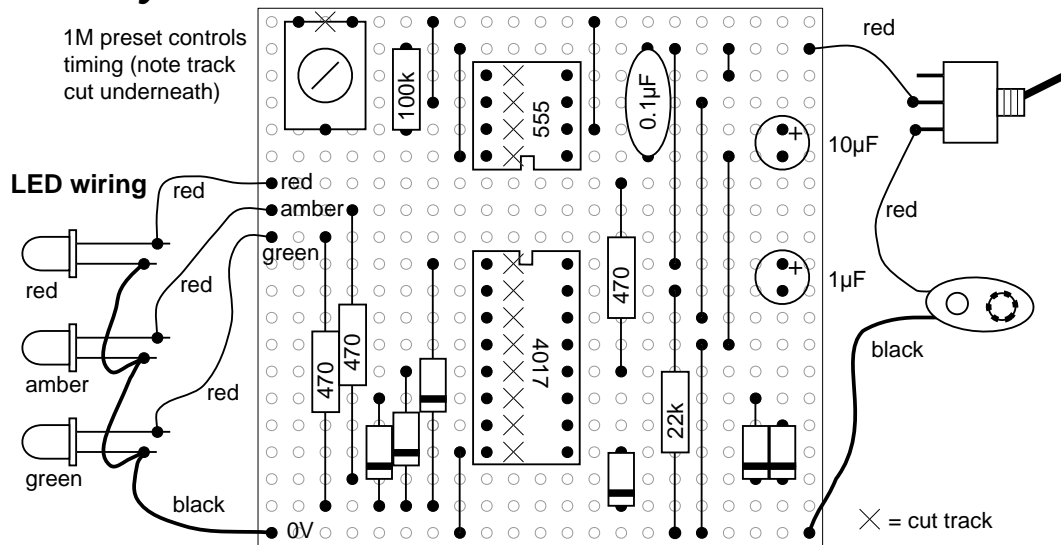

## Circuit diagram

